

# TECHNOLOGICAL ADAPTATION FOR AN ELECTRIC WHEELCHAIR, APPLYING A MODULAR APPROACH

Ruth Edmy Cano Buitrón<sup>1</sup>, José. Isidro García Melo<sup>2</sup>, Juan Carlos Burbano Jaramillo<sup>3</sup>

<sup>1</sup> Mechanical Engineer– Universidad del Valle, Cali, Colombia. Contact: ruth.cano@correounivalle.edu.co

<sup>2</sup> PhD Mechatronic Engineer, M. Sc in Automatic, mechanical engineer - Universidad del Valle, Cali, Colombia. Contact: jose.i.garcia@correounivalle.edu.co

<sup>3</sup> PhD in Mechanical Engineer, M. Sc in Automatic Systems, Universidad Tecnológica de Pereira. Colombia. Contact: jburban@utp.edu.co

## ABSTRACT

Supporting products, such as electric wheelchairs, help people with disabilities integrate into society. However, often, in developing countries such as Colombia, the industry in this field it is still in the process of supplying consolidation of demand through imports. In addition, the socioeconomic situations of some users commonly demand the re-use of these products. In this context, the technological realization of adaptations to these products is common. Considering the serious physical consequences that could induce an inadequate technological adaptation to electric wheelchairs, it is necessary to advance in the definition of successful procedures that integrate synergistically theories and design tools in different domains, such as: mechanical, electronic and science computing. Thus, this paper presents the integration of modeling tools, formal and semi-formal, such as user-centered, IDEF0, UML, Petri Network, CAD, CAE, among others, to ensure technological adaptations using a modular approach in a chair design used electric wheelchair that would allow their re-use to new operating conditions imposed by another user. The structural flexibility as evidenced by the approach used promotes compliance with future requirements for possible re-use of another user.

**Keywords:** *electric wheelchair, modular approach, user centered design.*

Recibido: 03 de Septiembre de 2015. Aceptado 04 de Diciembre de 2015.

*Received: September 3rd, 2015. Accepted: December 4th, 2015.*

## ADAPTACIÓN TECNOLÓGICA PARA UNA SILLA DE RUEDAS ELÉCTRICA, APLICANDO UN ENFOQUE MODULAR

### RESUMEN

Los productos de apoyo, como las sillas de ruedas eléctricas, ayudan a que las personas en situación de discapacidad se integren en la sociedad. Sin embargo, frecuentemente, en países en desarrollo, como Colombia, la industria en este campo aún está en proceso de consolidación abasteciendo de la demanda mediante importación. Adicionalmente, la situación socioeconómica de algunos usuarios demanda, comúnmente, el re-uso de este tipo de productos. En este contexto, es frecuente la realización de adaptaciones tecnológicas a estos productos. Considerando las graves consecuencias físicas que pueden inducir una inadecuada adaptación tecnológica a sillas de ruedas eléctricas, se hace necesario avanzar en la definición de acertados procedimientos que integren sinérgicamente teorías y herramientas de diseño en diferentes dominios, tales como: mecánica, electrónica y ciencias de la computación. Así, este artículo presenta la integración de herramientas de modelado, formales y semiformales, tales como: diseño centrado en usuario, IDEF0, UML, Red de Petri, CAD, CAE, entre otras, para asegurar adaptaciones tecnológicas usando un abordaje modular en una silla de ruedas eléctrica usada que permitiera su re-uso a las nuevas condiciones de operación impuestas por otro usuario. La flexibilidad estructural evidenciada por el abordaje utilizado favorece el cumplimiento de futuros requisitos por un posible re-uso de otro usuario.

**Palabras clave:** DCU, enfoque modular, silla de ruedas eléctrica.

*Cómo citar este artículo:* R. E. Cano, J. I. García y J. C. Burbano, "Technological adaptation for an electric wheelchair, applying a modular approach" *Revista Politécnica*, vol. 11, no. 21, pp. 57-74, 2015.

## 1. INTRODUCTION

In [1] are defined the support products for people with disabilities, like those tools that allow a complete inclusion and participation of those who have a limited performance. It implies that the technology has to respond to the particular needs and environment of the people with disabilities. In addition, it has to offer the help needed. In order to, this technology has to be of an easy maintenance, simple to operate and available on any place where the user may reside. However, in developing countries, where support products are imported, as Colombia, a variety of problems with the characteristics mentioned formerly, resulting in inconvenient before and after acquiring it. A particular case, for example, many users of electric wheelchairs have a number of drawbacks associated with premature controller integrated boards damages, which are generated by the deterioration of the roads where they circulate, the climate of the region, among others factors [2]. Added to this, the repair and maintenance of wheelchairs can be costly, because on one hand, the parts are imported, and on the other hand, in Colombia about 61% of people with disabilities do not receive any income for subsistence [3]. Additionally, sometimes the mechanical configuration does not address ergonomics aspects and standards that induce physical injury to the user [2]. As a result, users of electric wheelchairs choose to stop using them.

The support products for disabled persons with reduced mobility in the lower body, more specifically, the electric driven wheelchairs, are intended to persons without enough force in the upper limbs, those who have mobility problems generated by high spinal cord injuries and deficiencies in the neuromuscular processes, or those who cannot tolerate the energetic effort of a propulsion because of a bad cardiovascular situation [4]. Thereby, the need of a wheelchair with characteristics that fits all these needs to avoid a future disease, results essential. In this context, the wheelchairs have to adequate to the following criterion:

- Customization (size of the person, weight and comfort).
- The user mobility (limited, partially limited, very limited).

The technology approach with a flexible structure that facilitates the viability of several parameters, such as: maintenance, availability of parts and independent operatively from the clinical case, user comfort and affordability on a national level. With this criterion, results convenient to apply a modular approach for the adaptation of an electrical wheelchair, understanding the modular term as the action of splitting a system in simpler subsystems, offering a functional autonomy and allowing interoperability with other subsystems. Thus, the different components can be organized in more complex subsystems with independent control systems communicating each by protocols of communication [5]. As a consequence, the system acquires an structural flexibility which facilitates both a technological and functional adaptation, for example: in case that a user of a wheelchair with a joystick command, needs another kind of command, this modular approach ease the implementation of this kind of needs, once a new command is adapted and reusing the other modules.

In order to identify technologies that use modular structures in their designs or adaptations, a literature review was conducted. In Table 1, a summary of the information is shown, where, despite the existence of modular designs in wheelchairs, they focus primarily on its structure and few in its control system and no cases of restoration wheelchair in disuse was found.

In this context, this project faced a problematic of flexibility, with a technologic approach considering the criterion mentioned above. A way of evaluating the proposals was taken as a case of study, a wheelchair of electrical in disuse. The product support was directed to Colombian adults in a situation of disability with reduced mobility in the lower body and full mobility in the upper body. Where, the wheelchair should be adapted also for people with partial mobility of the upper body, without including cases mental disabilities or congenital malformations and neuromuscular diseases. For this, it was proposed a design procedure that integrates different theories and tools to ensure technological adaptation with a modular approach to facilitate the fulfilling of a number of functional requirements

defined with the wheelchair users. In turn, the solution presents an increase on the index of maintenance, once the modular approach ease the diagnosis as the correction of a failure in those modules. Also, the adaptation considered a seat that improves the posture and the comfort of the users previously described, in according to the anthropometric measures. Finally, it is also clarified that even this job does not aim to resolve the totality of the flexibility problems on the structure in this support products for persons with disabilities, it aspire to contribute making available a competitive final product, compared to the wheelchairs that are currently on the national market.

In section two a description of the procedure followed during the project was presented, requirements for adaptations, the structural assessment, the modeling IDEF0, UML and Petri nets were developed and a brief description of the designs from these were exposed. The section three shows some of the designs implemented followed by the results of the

test runs and finally in section four conclusions were presented.

## 2. MATERIALS AND METHODS

### 2.1 Working Procedure

The design and implementation of adaptations follow a structured procedure that integrates four stages: requirements, structural evaluation, modular adaptation, implementation and proves, see Fig. 1. Requirements stage considered to use some techniques of user centered design (UCD) and heuristic procedures, such as decision matrix [11]. Where, it was necessary considered a user as not only people who drives the wheelchair, also their families and health professionals. Also, a technologic comparison between different kind of wheelchairs was considered [1], [4].

**Table 1.** Similar projects

| REFERENCES | MODULAR - Yes [Y]/No [N] |                 | DESCRIPTION  |
|------------|--------------------------|-----------------|--|
|            | MECHANICAL STRUCTURE     | CONTROL SYSTEMS |  |
| [6]        | Y                        | N               | Control system activated by voice to a wheelchair  |
| [7]        | Y                        | Y               | Design of a wheelchair /bed reconfigurable. The design contains a control unit, a unit of position adjustment and data acquisition unit. |
| [8]        | Y                        | N               | Wheelchair controlled by facial movements  |
| [9]        | Y                        | N               | Wheelchair with embedded systems capable of recognizing images and moving by itself.   |
| [10]       | Y                        | N               | Wheelchair two positions reconfigurable  |

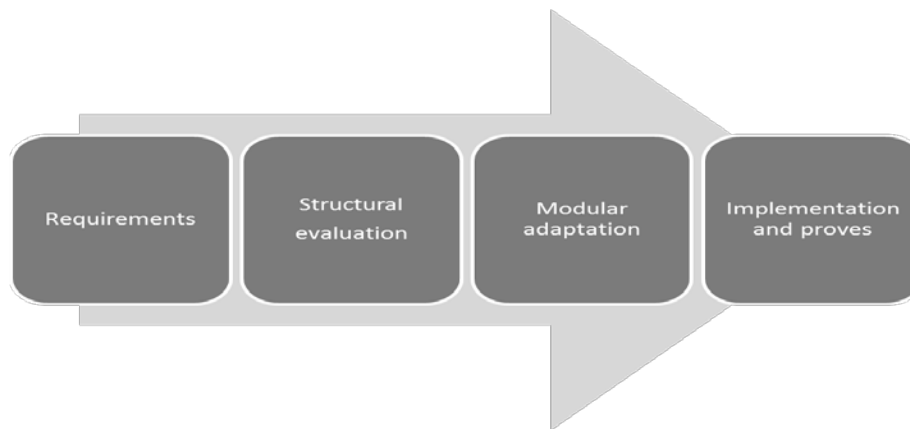

Fig. 1. Working procedure

Once, functional requirements were identified, in the second stage was defined a procedure to verify the wheelchair was suitable for use, through an assessment of the structural vulnerability of the wheelchair, considering national and some international standards.

Then, in the third stage, a design procedure was followed in accordance with the results obtained in the earlier stages. In order to achieve this goal, it was necessary to use modeling tools to represent the structural and dynamic characteristics of the modular system to adapt, where an IDF0 representation defines a functional structure of the system. Meanwhile, the UML model represented the interaction between the user and the wheelchair and the interaction between the different components and validation thereof, through a formal tool, such as Petri nets. The models let to design each of the modules and its functions, such as the control, power and display modules, and the design of additional mechanical adjustments to the structure of the wheelchair including controls used by the new user. In the last stage, all designs were implemented with local technology in order not to incur the same problems posed by imported wheelchairs with embedded technologies. In addition, some test were conducted based on the standards, such as: NTC 4265, 4266, 4267, 4268, 4269, COVENIN 2910, 2912, 2915, 2916 and ISO 7176:13, in order to validate proper functioning of the wheelchair and the technological adaptations.

## 2.2 Requirements

In the project the use of heuristic procedures for the specification of functional requirements was made. To identify them, it was necessary to take advice

from different users to create a general panorama of the actuals pros and cons of the wheelchairs, which they were related.

Under the methodology UCD, the user has to be an active character during the process of design. In consequence, it was necessary to make some surveys, there were invited six users of electrical wheelchairs (UPSRE), according to the following criterion of inclusion, no matter the gender, part of the Colombian labor population, users of technical helps (wheelchair) with chronical pain or painless. Those criteria allow comparing the needs of each user that use the same wheelchair but with different disabilities. In addition two health specialists were interviewed, a neurosurgeon and a physiotherapist and three relatives of the UPSRE. The development in detail of the process for the characterization of requirement was specified in [12]. The characteristics that the wheelchair must have were:

### a. *Mechanic characteristics*

- It must have four wheels, two small and solid front wheels, two pneumatic rear wheels and two rollover accessories on the rear part of the wheelchair.
- The footrest has to allow an adjustment of elevation between the 0 and 45 degrees.
- The armrest and footrest have to be adjustable to the anthropometric measures of the Colombian labor population between the ages of 20 and 39 years old with percentile 50th female and percentile 70th male.
- The chair has to allow the addition of accessories, such as: work tables or the use of elements for sun or rain protection.

*b. Electrical and electronic characteristics*

- The circuits must be organized by modules with defined functions and have to communicate through the communication protocol RS458. Modular approach permit plug and unplug different devices, in this case the driver controls.
- The principal command is a joystick and the secondary are a chin control and a remote control used by another person in case that the driver could not use the principal controls.
- The wheelchair must use gel batteries [2]. The control panel has an LCD and a manual board in an additional module to configure the control to use.
- The wheelchair brakes must be magnetic.

*c. Control characteristics*

- The system must count with a charge indicator for the battery and a system of auto-power off if the wheelchair is in operation but hasn't received any instructions passed 10 minutes approximately
- A reset button in case the user asks for contradictory actions or to get the wheelchair back into its initial state. It must count with a reverse indicator.

*d. Ergonomic characteristics.*

The wheelchair must count with an ergonomic seat and preferably use anti-bed sore cushions. The adaptations between the different anthropometric measures must be easy to make. For the particular case of this project, it will only be taken on account the variation of the geometry of the armrest and footrest.

**2.3 Structural Valuation**

Due the wheelchair selected by the project was not used for a long time, it was necessary to evaluate it. A structural analysis was made following the Colombian technical standards. A summary of the valuation is shown next.

*a. Static analysis.*

To fulfill the static analysis, the Colombian technical rules (NTC) were initially consulted, those rules establish the general aspects to determinate the stability of a wheelchair; the max overall dimensions and the appearance characteristics.

The characteristics of a wheelchair were identified under the specified methods by the rule NTC 4265 [13] and 4266 [14], where is specified the methods to determine the static stability of a wheelchair and the efficiency of its brakes respectively. On the other hand, the NTC 4267 [15] specifies the methods to determine the max overall dimensions and the wheelchair weight, The NTC 4268 [16] specifies a method to classify the wheelchair in accordance with its particularities and the NTC 4269 [17] specifies the measures.

According to [16], the NTC 4268 the wheelchair was classified with the code 96154, this digits represent the Electrical motor wheelchair, to drive an electrified energy (9), a total width of 660mm to 700mm and the diameter of the large tires more than 250mm and the small tire from 180mm to 260mm (6). The seat and its back inclination nonadjustable (1), Armrest of an adjustable height and angle of the footrest manually adjustable (5), detachable, that is to say its overall dimensions can be reduced by disjoining the wheelchair in components without the use as tools (4).

Using the program Autodesk Forceeffect, [18], an schema with links was made, those links represent the wheelchair and the loads it has to take on an horizontal plane. For this analysis, it was assumed that the rear wheels had the manual brakes activated (this does not allow movements on the plane). A load distributed over the seat (Q2) represented the weight of the user. The forces exerted by the user arms were also taken on count by a punctual load in the armrests (F1) and a load distributed over the back of the seat represent the force of the user exerted by its back (Q1). The distributed loads were considered constant in all the pressure points that usually are presented on the UPSR. Additionally the calculus were made considering that the wheelchair was on a horizontal plane, therefore the external forces affecting the balance and the friction effects were not taken on count. With the program were calculated the reactions on the different elements that compose the wheelchair and its respective shear and moment diagrams. The magnitudes of the forces were taken from [19], [20]. From the analysis made was observed that the reactions of the rear and front wheels (E and F reactions) 334.34N y 252N, respectively, being those the maximum values.

*b. Dynamic analysis*

This analysis was made to determine the required potency to impulse the wheelchair and move it through sloping ground (maximum slope according to the Colombian regulations). To carry out this analysis, a free body diagram of the wheelchair was made with the forces that affect it, Fig. 2.

The free body diagram shows the forces that affect the wheelchair on a sloping ground of  $20^\circ$  [12], Keeping in mind that the sloping ground according to the regulations shouldn't be over  $6^\circ$ . However in the Colombian scope can be found slopes over that value. The diagram shows the forces that act:

traction and friction on the front and rear wheels. Normal force at the plane and its own weight, applied at the center of gravity (22 cm, 55 cm) with respect to the origin. Where the weight includes the wheelchair (50kg) and the user (100kg) and the necessary force to impulse the wheelchair, since the interest points are the rear wheels, having in mind the assumption that it must generate the higher momentum to displace the wheelchair, a second free body diagram was made, considering that the loads acting are due to the weight of all the system at its center of gravity, and the forces that act over the rear wheels of the previous free body diagram (Fig. 3).

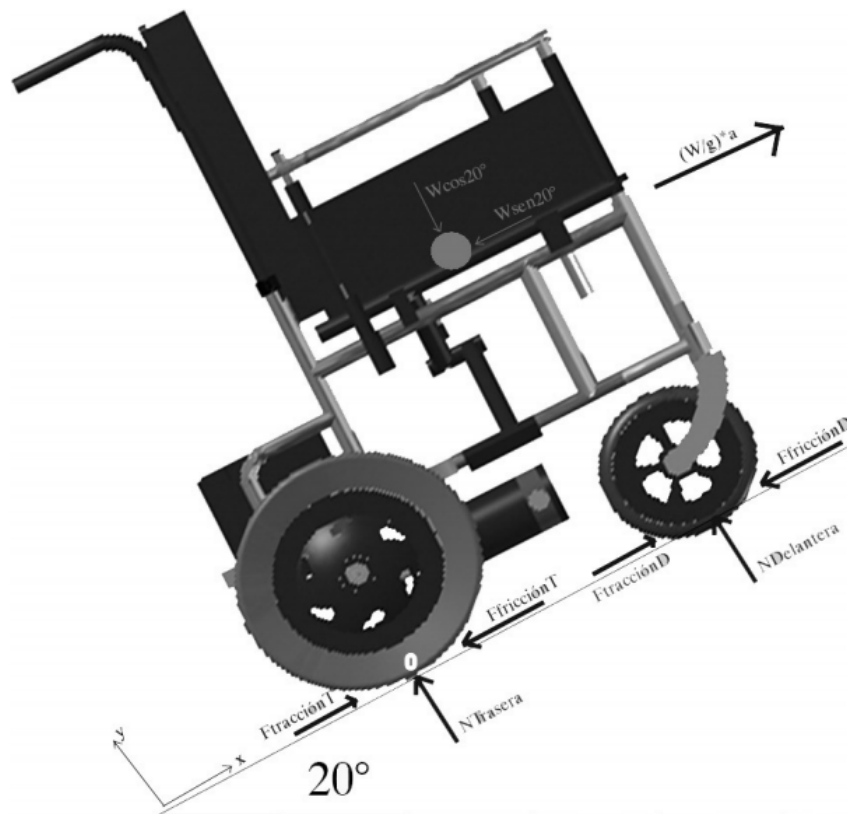

**Fig. 2.** Free body diagram of the wheelchair

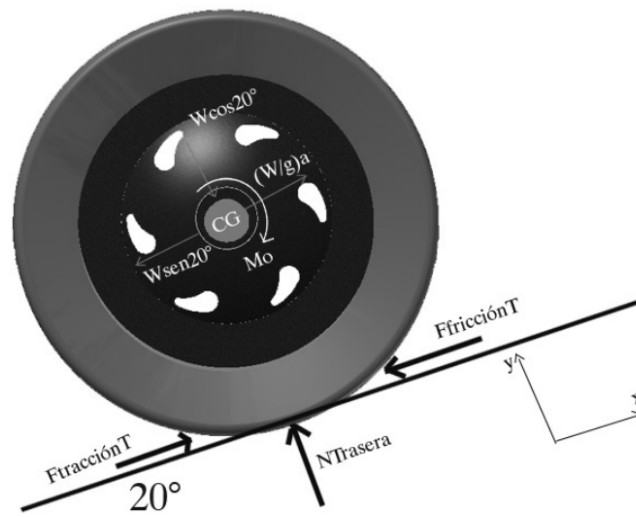

Fig. 3. Free body diagram of the rear wheels.

The given results showed that in order to a person of 100kg ascend a  $20^\circ$  slope on the wheelchair, are required 0,5 HP. Due to the actual engine can only give 0,5HP, it can be concluded that these are suitable for the use on the established conditions in this numeral. Once this was identified, a model was made to characterize the relation between the voltage applied to the engine and the speed developed by it according to the characteristics of the engine [21]. The simulation of the obtained model was made on the Matlab environment [22]. Based on the collected information, the expression which characterizes the speed of the motor was determined to indicate the speed in km/h on an LCD. This approach avoids the use of instrumentation for the direct census of this variable, like a tachometer.

### c. Analysis of Resistance of materials

To make a solution through the Finite Elements Analysis (FEA) there were made a series of steps, such as the definition of geometry, specification of the regimen to study, assignment of the physical properties of materials, assignment of boundary conditions, application of the loads. The simulation of the obtained model was made using the software Abaqus [23].

Definition of geometry: With the static analysis was verified that the base of the wheelchair, frame, is the component that supports greater loads, because of that, it was considered as the object of study. The geometry showed on the Fig. 4 was drawn in the parametric CAD 3D Autodesk Inventor [24]. The frame of the wheelchair comprises two identical parts joined together with a pair of carbon steel tubes with a diameter of 25mm and schedule 40, forming an X; for the model, it was assumed that the loads on each frame were identical given its geometry; this characteristic allows to perform the analysis considering half of the structure forming the wheelchair chassis.

The mesh was made distributed uniformly throughout the geometry unrefined located. It started with a mesh of 0.01 to 0.00475 using tetrahedral elements of the type C3D10 to C3D17. There were made 11 iterations to determine the mesh size to allow an independence of the results to it with a relative error criterion less than 5%. The Von Mises effort maximum, 115MPa, was presented on the area close to the union of the frame to the rear tire and a maximum strain of  $0,48\mu\text{m}$  located on the same area.

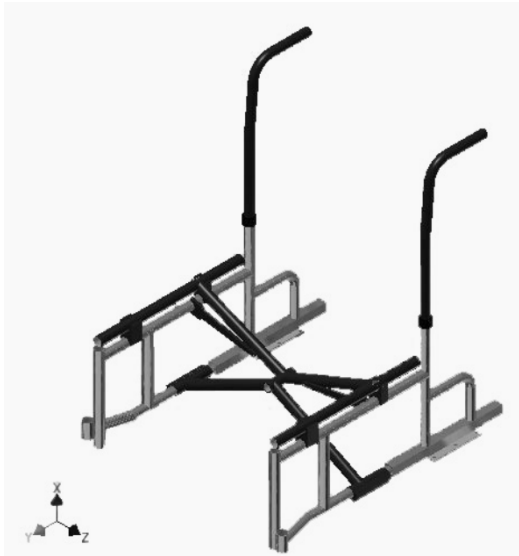

**Fig. 4.** Geometry of analysis.

With the obtained results was determined the value of the structure security factor with the Von Mises criterion [25]. The maximum effort obtained on the simulation presents a security factor of 1.96, indicating that the actual model can carry a person up to 100 kg securely. Overall, the analysis allowed to verify that the current chair be suitable for use.

## 2.4 Modular Adaptation

Once it was identified that the structure of the wheelchair was suitable, a model of a modular wheelchair was raised.

The electric wheelchair with a modular approach (SREAM) was modeled using three approaches UML [26], IDEF0 [27] and Petri nets [28]. From UML were used the activities and case of use diagrams, those, along with the Petri nets allowed to determine the behavior of the system and to validate its correct behavior. Also IDEF0 allowed to define its architecture and the interactions between the modules that make the wheelchair and the surroundings.

The models were made by successive refinements, Top-Down, to assure a functional structure of the product. A detailed approach of the process of modeling with the UML tools (activities and case of

use diagrams), IDEF0 and Petri nets of this project is detailed on [29] and [30].

In Fig. 5 the general IDEF0 diagram of the wheelchair is shown. The entrances are in the left side, in this case a power supply. On the right side the outputs of the system, such as the user messages and, wheelchair movements and devices position change (footrest and armrest). At the top, there are the controls (user instructions).

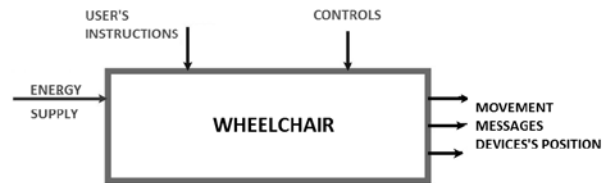

**Fig. 5.** General IDEF0 - wheelchair.

An example, a detailed representation of the electrical module can be seen in Fig. 6. Where, different voltage levels, 5V, 12V and 24V were identified for the entire system. The power module consists of three interconnected modules, control, power and visualization. The control module and visualization require a 5V supply to perform their functions. Furthermore, the control module receives a signal from the user information through the controls used. Power Module outputs are due to the responses of the power modules and visualization, and these are the torque and messages to the user, respectively. Where in the first module requires a 24V power supply.

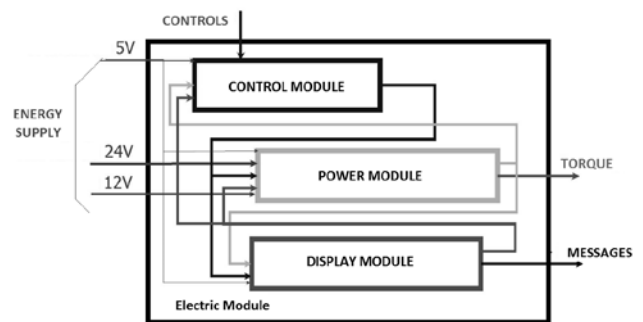
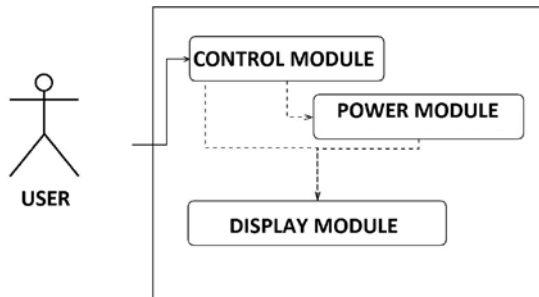

**Fig. 6.** IDEF0 diagram - Electric Module.

UML diagrams use case, Fig. 7, document the behavior of a system from the point of view of the



user. It is noted that the user interacts with the control module, which communicates with the display module and power, which in turn communicates with the display module. A use case can specify a desired behavior but not to dictate how it is done, it should describe scenarios for viewing as their sequence.



**Fig. 7.** Use cases diagram.

Use cases and scenarios of operation were needed to define the activity diagrams. Each one describes the flow of activities to be performed by wheelchair modules and some specific functions. As an example shown in Fig. 8 the activity diagram of the function control module "LeerDatoControl"

Once the operating modes and activity diagrams were defined, the functional model of the system in Petri nets (PN) and its respective validation were performed following these steps:

- A place to each functional status was assigned.
- Possible transitions between states were defined: for each possible change from one state to another, is assigned a transition and connects to the corresponding arcs.
- Shooting preconditions were added for each transition

According to [31] a model validation determines whether it is consistent with the purposes of the designer. In project development, validation is

performed based on the properties exhibited by the model (safety, temporal properties and properties vivacity). Aspects such reachability of the states and conflicts should be checked.

Initially, the model of general dynamic between functional states was developed; a place to every state and the possible transitions between states were defined, an example is shown in Fig. 9, it is observed that the transitions have a hierarchy, ie, each transition corresponds to a respective network.

To verify each model, a simulation was made using CPNTools [32]. It was observed that the models showed no blockages or conflicts. Finally, Petri nets model permits verify the system behavior, and they were implemented accompanied by activity diagrams in the design of the different modules in the wheelchair.

#### *a. Mechanic adaptations*

This paragraph shows a description of the different adaptations designed for the prototype. The design of the mechanic adaptations was made to the footrest and armrest, the coupling of the rear wheels to the motors. However, it soon became clear that the design of a management arm attached to the midi- joystick command was needed, and also holders and a restraint system to the principal command and a seat belt. In addition, the design of the cases for the protection of the controls and modules was made.

As an example, the Fig. 10 and the Fig. 11, show the design for the holders, the different operation controls of the wheelchair, the visualization module and the protection case.

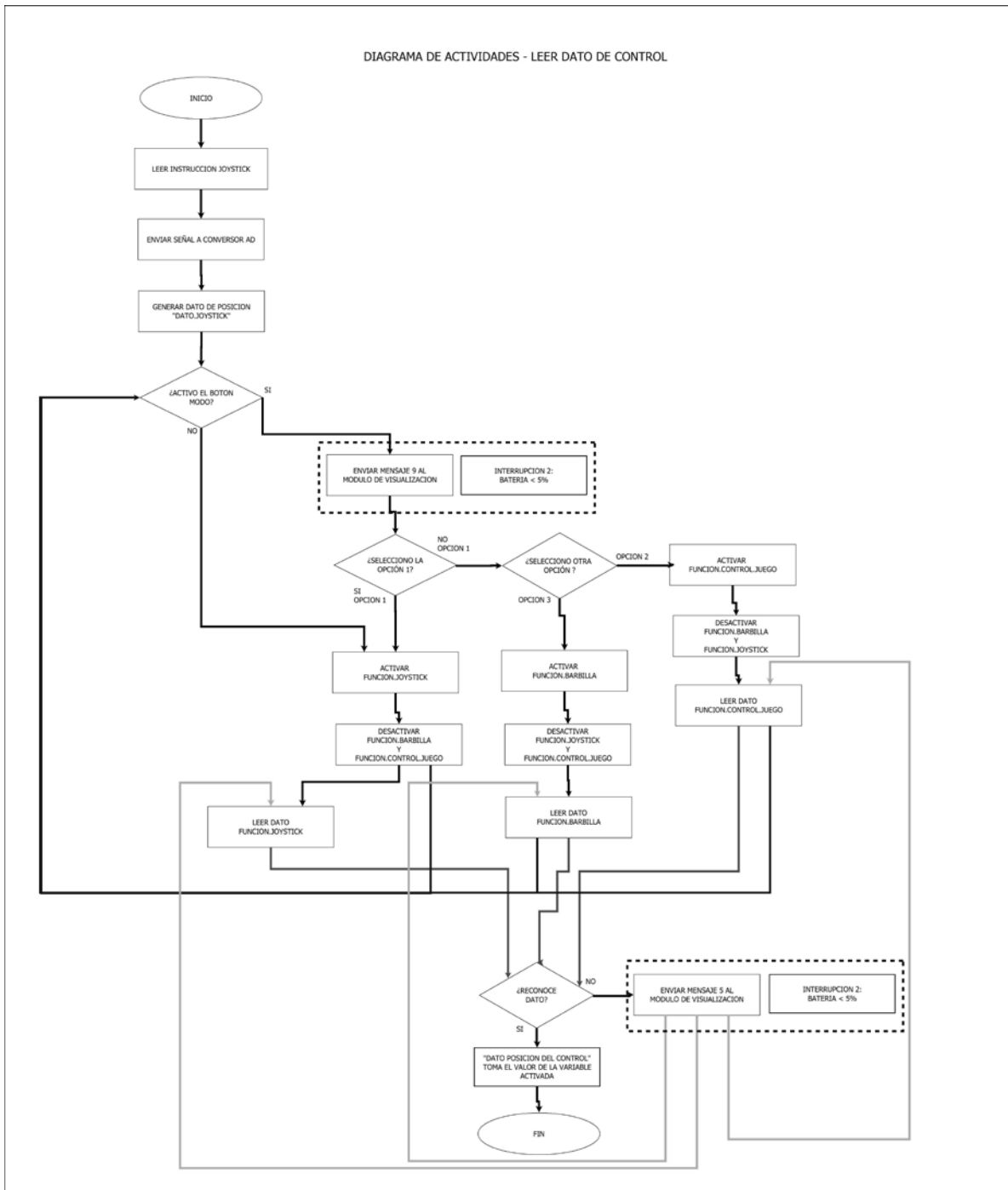

Fig. 8. Activity diagram - "LeerDatoControl"

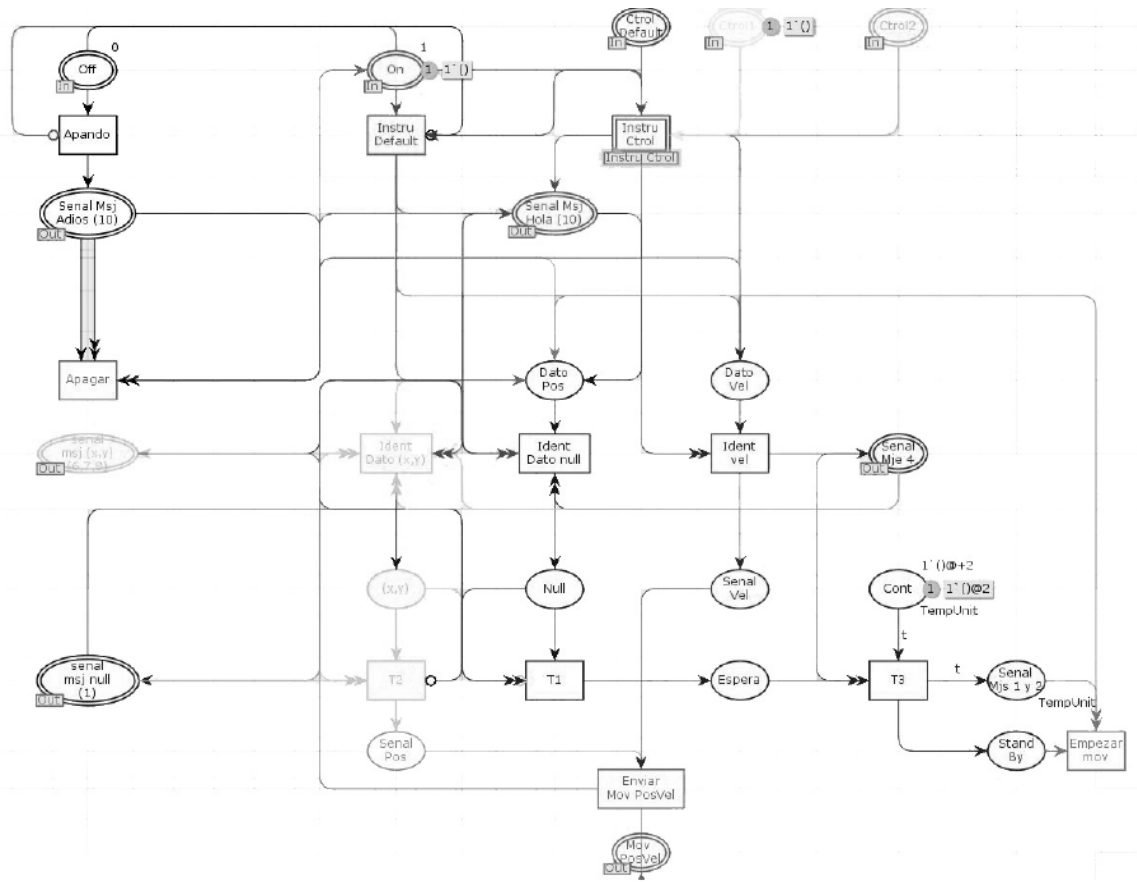

Fig. 9. Control module PN

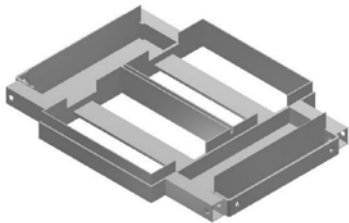

Fig. 10. Holders.

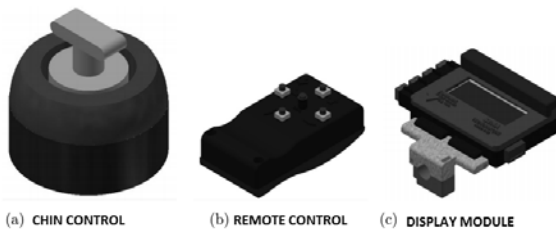

Fig. 11. Design of modules and controls.

*b. Electronic adaptations*

The design of a modular architecture was thought to respond to the requirements. A representation of the different components of the electric module, defined in the IDEF0 diagrams, is shown in figure 12. It also shows the wheelchair drive, which consists of a pair of servomotors, a joystick, midi-joystick, and a remote control, sending an analog and pulse signal, respectively, a control command card, which uses an RS458 communication with power control and visualization cards. These three circuits get the power from a buck source regulated to 5 V. The power control also sends a PWM signal to a regulatory power card powered with 12 V, to reduce the float voltage due to the noise and filters the signal. A bank receives the regulated signal and sends a source-drain voltage to the gear motors to regulate the speed thereof. The power module

consists of the control card, regulatory card and the bank. The visualization module consist on a control card and a visualization screen communicated by a serial port. The description of the different components of the electric module is explained above. The design and simulation of the modules were made on the program AVRstudio [33] and Proteus [34]. This configuration allows easy identification of the damage of a module without replacing the other.

As an example, the control module consists of the control board control and user interface. The key component of the control card is a microprocessor Atmega32 [35], which interprets each control signal connected. Next, the instructions are encoded in a string and sent through a RS458 communication protocol to other modules. Additionally, it has a voltage divider to measure battery status. The control module allows the user to select a control device through a removable panel, which consists of four buttons and a power button:

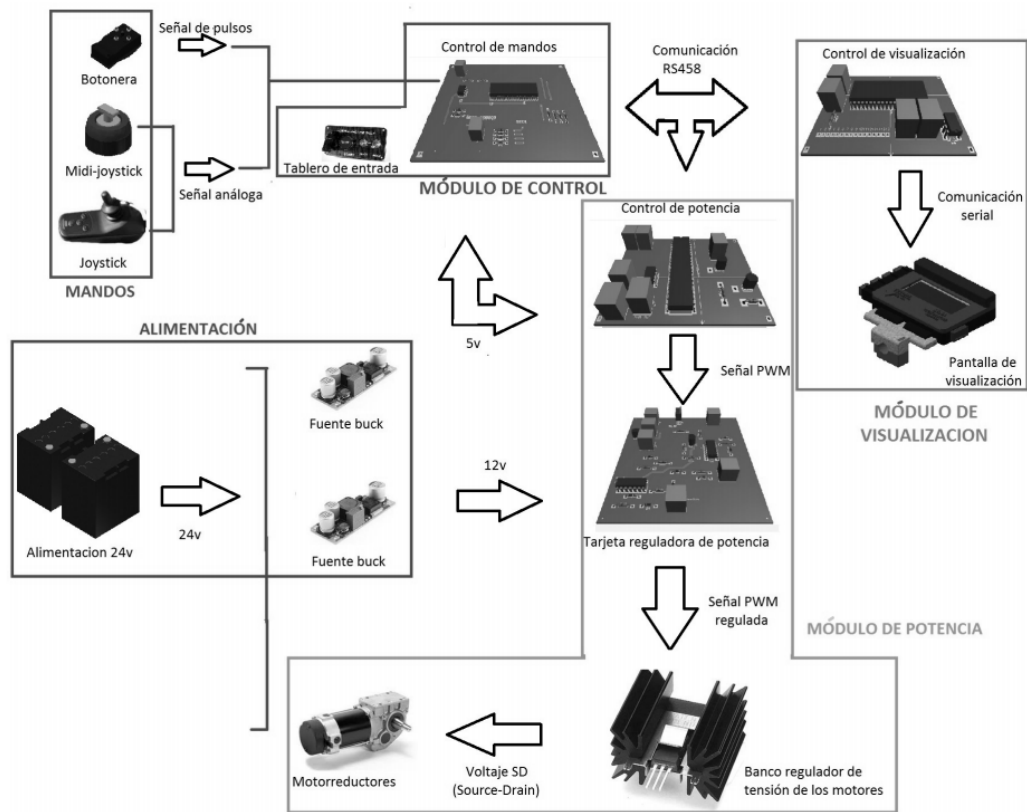

Fig. 12. Electric module connection.

- Mode: Displays the user a selection menu that lets you choose from three options for controlling the chair.
- Mode 1: Select the command has wheelchair default joystick.
- Mode 2: Select control of chin
- Mode 3: Selects the remote control.
- Power: This starts, restart and shutdown the wheelchair.

### 3. RESULTS AND ANALYSIS OF RESULTS

#### 3.1 Implementation of the modular designs

##### a. Mechanic adaptations

Initially, the wheelchair and its components were built. Before making any modifications to the wheelchair structure it was necessary to make a conditioning to the structure. A general cleaning and

the polishing of some affected surfaces was made and there were taken off the elements that the former owner had, which were not useful to the prototype.

To the implementation of the proposed adaptations (cases, holders, chin control, remote control, and the chin control support) was used the rapid tooling. For this purpose, the project was registered in the area of design and engineering of the Tecnoparque Sena. Where, the design and making of the cases for the wheelchair and the midi-joystick support. For the implementation, a PROJECT SD 3500 printer was used, with acrylic resin VISIJET as basic material.

*b. Electronic adaptations*

Once, the electric modules were design and tested using a hand fan as the actuator to check the correct operation, the modules were ensemble using the engine of the wheelchair. The first tests were made without a passenger aboard, in the Fig. 13 are shown the initial assembly process. In (a) are show the tests made with the fan, in (b) is shown the assembly process and the tests without a passenger aboard.

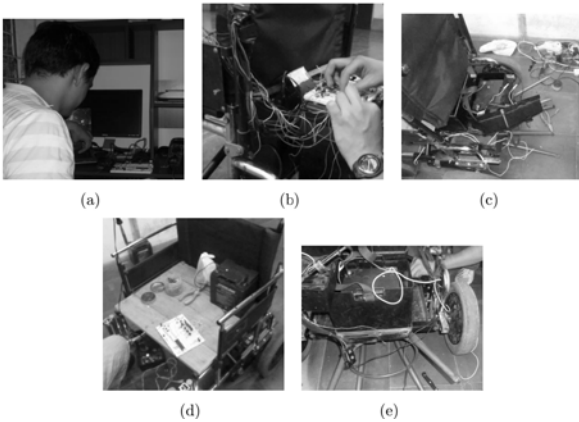

**Fig. 13.** Tests and initial assembly.

Once, these tests without a passenger were made completing the expectations, the tests were made again with a passenger using two potentiometers as the joystick, Fig. 14. The test was useful also to

modify the programming and configuration of the different modules to improve its operation, according to the requirements.

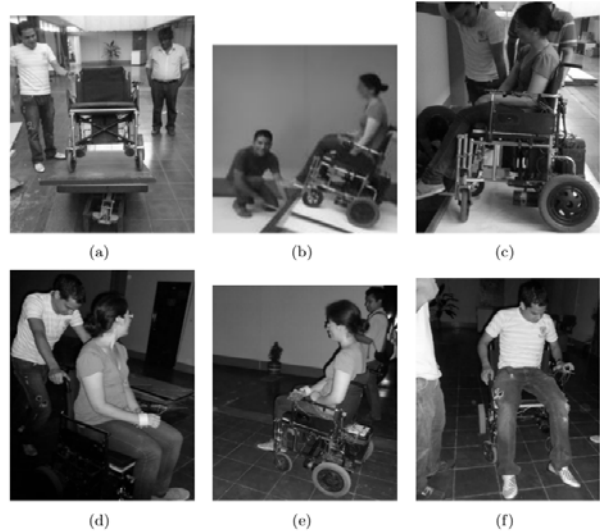

**Fig. 14.** Functionality tests.

The integrated were made once the tests were over. Printed circuit boards were manufactured in Tecnoparque, Cali, in the area of electronic and telecommunications. First, the printed circuits were designed in Proteus, some had two conductive layers.

*c. Electrical installation*

In the Fig. 15 (a) to (d), the assembly of the different components is shown, to ease the adjustment of the different cards, the integrated were located on the side compartment of the holders, so on the left side are the controls of the wheelchair and on the right side are the power controls. For the left side components it was necessary to make support bases to ease the location and removing and the other side elements were located in sinks.

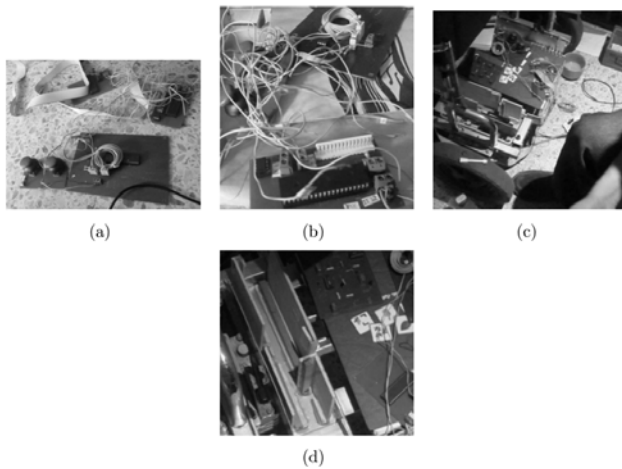

Fig. 15 Electrical installation.

*d. Project costs*

Table 2 shows the general report of costs, supplies and services, generated through the project execution. Each column corresponds to the different source of resources in Colombian pesos.

**Table 2** General expense report (2014 prices, COP).

| SOURCES           | STUDENTS           |                    | UNIVERSITY       | Tecnoparque      |
|-------------------|--------------------|--------------------|------------------|------------------|
|                   | SPECIES            | CASH               | SPECIES          | SPECIES          |
| Uso equip.        | \$ 370.000         | \$120.000          | \$310.000        | \$800.000        |
| Materiales        | \$-                | \$ 1.483.796,00    | \$-              | \$-              |
| Servicios         | \$-                | \$ 285.000,00      | \$-              | \$-              |
| Transporte        | \$-                | \$ 212.000,00      | \$-              | \$-              |
| Imprevistos       | \$-                | \$ 300.000,00      | \$-              | \$-              |
| <b>Total ftes</b> | <b>\$370.000</b>   | <b>\$2.400.796</b> | <b>\$310.000</b> | <b>\$800.000</b> |
| <b>TOTAL</b>      | <b>\$3.880.796</b> |                    |                  |                  |

**3.2 Functional Tests**

In order to characterize the final prototype of the wheelchair, various test were made, bases on the rule ISO 7176 [36] and their Colombian counterparts NTC, Venezuelan COVENIN encompassed in three categories: sizing, stability and performance. Due to the availability of standards, in the Table 3 are shown the used standards.

The following test results were obtained:

*a. Sizing*

The wheelchair without a passenger weighs 51kg with all the accessories. In addition it meets the standard NTC 4269 and does not exceed certain maximum dimensions.

*b. Stability*

For each test were made three measures, it showed that for the blocked brakes test forward, maximum lift angle of 21 ° was obtained, no slip occurred during the test. In the test with locked brakes in the transverse direction an angle of 22 ° was obtained. In the stability tests with unblocked brakes there was a slip to the 7° and 6°, respectively. The application of the NTC 4265 allowed checking that the wheelchair met the restrictions for this project. For the dynamic stability the chair did not present overturning during the test. In one of the tests with a ramp of a higher slope a drop in the rated operating conditions with the maximum speed was obtained, it can lead to a lifting of a tire. Therefore, is not recommended to use the wheelchair on ramps over 6°, should be aware that this results were obtained with a dummy of 75kg, that is to say, a wheelchair of 125kg.

*c. Performance*

During the tests the brakes did not fail or present a friction loss (slip). However it did present instability at 21°. The tests from the rule 2912, determine that the maximum speed of the wheelchair is 5 km/h, which release it from the application of the rule

Covenin 2910. It was determined that the wheelchair runtime for a user of 75kg is 6 hours and 50 minutes. And also was verified that the wheelchair can easily overcome obstacles up to 6mm.

**Table 3.** Standards apply to the functional tests

| STANDARDS COUNTERPARTS  |   |                      |  |                     |  | USED    |
|-------------------------|---|----------------------|--|---------------------|--|---------|
| INTERNATIONAL STANDARDS |   | VENEZUELAN STANDARDS |  | COLOMBIAN STANDARDS |  |         |
| ISO 7176-1:1999         | Determination of static stability   | COVENI N 2908-99     | Determinación de la estabilidad estática   | NTC 4265:1997       | Determinación de la estabilidad estática                         | NTC     |
| ISO 7176-2:2001         | Determination of dynamic stability of electric wheelchairs  | COVENI N 2915-98     | Determinación de la estabilidad dinámica de las sillas de ruedas eléctricas                        | -                   | -  | COVENIN |
| ISO 7176-3:2012         | Determination of effectiveness of brakes  | COVENI N 2909-98     | Determinación de la eficiencia de los frenos   | NTC 4266:1997       | Determinación de la eficiencia de los frenos                     | NTC     |
| ISO 7176-4:2008         | Energy consumption of electric wheelchairs and scooters for determination of theoretical distance range | COVENI N 2910-98     | Determinación del consumo de energía de la silla de ruedas eléctrica                               | -                   | -  | COVENIN |
| ISO 7176-5:2008         | Determination of dimensions, mass and manoeuvring space   | COVENI N 2911-98     | Determinación de dimensiones globales, masa y espacio de giro                                      | NTC 4267:1997       | Determinación de las dimensiones totales, masa y espacio de giro | NTC     |
| ISO 7176-6:2001         | Determination of maximum speed, acceleration and deceleration of electric wheelchairs                   | COVENI N 2912-98     | Determinación de la velocidad, aceleración y desaceleración máxima de la silla de ruedas eléctrica | -                   | -  | COVENIN |
| ISO 7176-7:1998         | Measurement of seating and tire dimensions  | COVENI N 2906-92     | Dimensiones máximas globales   | NTC 4269:1997       | Silla de ruedas: dimensiones máximas globales                    | NTC     |
| ISO 7176-10:2008        | Determination of obstacle-climbing ability of electrically powered wheelchairs                          | COVENI N 2916-98     | Determinación de la capacidad de las sillas de ruedas eléctricas para subir obstáculos             | -                   | -  | COVENIN |
| ISO 7176-11:2012        | Test dummies  | -                    | -  | -                   | -  | ISO     |
| ISO 7176-26:2007        | Vocabulary  | COVENI N 2905-98     | Nomenclatura, términos y definiciones  | NTC 4268:1997       | Clasificación por tipo con base en características de aspecto    | NTC     |

*d. Characterization of circuits*

In this paragraph are shown the results from the functional rating of the electric circuits that integrate the different modules, described in previous chapters.

*Power module:* To check the operation of this module, the voltage outputs of the circuit were

measured, to verify the integrated communication Max 487 [37], protocol RS 485. To prove the modulated signal PWM, the voltage output of the motors was measured, the percentage error in the measurement of the RS 485 protocol was 4.6 %. Meanwhile the percentage error of the modulated signal was 10%. See Table 4.

**Table 4** Power module tests

| Puntos de medición   | Valor teórico | Valor Práctico | Error porcentual |
|----------------------|---------------|----------------|------------------|
| P3 con respecto a P4 | 5.0VDC        | 4.77VDC        | 4.6%             |
| P1                   | (0 - 5) VDC   | (0 - 4.5) VDC  | 10%              |
| P2                   | (0 - 5) VDC   | (0 - 4.5) VDC  | 10%              |

*Control module:* The test for this module consist in measuring the signal range that the Joystick should send. Considering that there was only measured the potentiometer on the Y position. The results are shown in the Table 5, where the measured voltages are close to the simulated.

**Table 5.** Control module tests

| Puntos de medición   | Valor teórico     | Valor Practico   | Error porcentual |
|----------------------|-------------------|------------------|------------------|
| P1 con respecto a P2 | 5.0VDC            | 4.6VDC           | 8.0%             |
| P3 con respecto a P2 | (0.0 - 2.5) VDC   | (0.0 - 2.6) VDC  | 4%               |
| P1 con respecto a P3 | (2.34 - 4.75) VDC | (2.34 - 4.5) VDC | 10%              |

*Visualization module:* For this module, the switching signal of the integrated and the ICD was verified. In the Table 6 are shown the measured values of the connection pins and in the Fig. 16 is shown the outgoing message used during the measurements.

**Table 6.** Visualization module tests

| Conexión                                     | Señal en voltios |
|--|------------------|
| RS Register Select                           | 1.2 V            |
| VDD  | 5V               |
| E Enable Data                                | 0.4V             |
| Pines 7-14 Bi-Directional Tri-State Data Bus | 0.5V             |

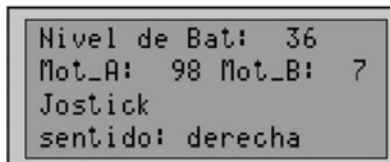

**Fig. 16.** Visualization module tests.

#### 4. CONCLUSIONS

Considering the scenario where in Colombia part of the demand for wheelchairs were supplied by

renewed or adapted wheelchairs, it is necessary to establish suitable procedures in the implementation of these technological adaptations for an appropriate inclusion of people with disabilities in society. In this context, the development of this work presented a systematic procedure, which guarantees a modular approach. For this, an expanded definition of user allowing clarity of requirements was considered. For the specification of appropriate technological adaptations it was considered an integrated vision of the system. Thus, various tools and theories were used considering national and international standards. Additionally, the technologic adaptations were not only proposed from the mechanic view, it also covers the control strategies and electronic components. To stablish the correct technological adaptations from the mechanic view, analytic and informatics tools were used to make a vulnerability analysis in the structure. Thus, the mechanic adaptations were defined to secure the performance of the wheelchair according to the regulations.

This modular approach evidenced being recommended for applications of technologic integration, as the related to the assistance technology, allowing assigning each module a specific task given its technology. Such, the integration and coordination assure the performance of the whole system. In addition, this facilitates the adjunction of more functions to the system, allowing an actualization or the adjunction of other module according to a new user of the wheelchair.

This Project made available an electric wheelchair with modular characteristics allowing a new user to maneuver it with three different controls. Thus, this configuration allows the change on any of the three modules and components without needing to replace all the integrated.

This solution certifies compliance with the requirements according the regulations for this topic. In a similar way, in order to verify performance of the electronic components, an



evaluation procedure was made. Finally, in the local context, it is important to highlight the benefits of this approach in social and economic terms, offering greater availability of this type of support products for people with disabilities,

## 5. ACKNOWLEDGEMENTS

We thank all those who facilitated the realization of this work, mainly Fundación libres sobre ruedas and Fundación mujeres sobre ruedas, Mr Elbio Caicedo and Mr. Eduardo Fernandez, Tecnoparque-SENA, Cali, which provided support for the electronic design and the Universidad del Valle, Cali, present throughout the project.

## 6. REFERENCES

- [1] Apress, "Normas de cobertura para sillas de ruedas con motor," vol. 13. Argentina, p. 4, 28-Dec-2008.
- [2] M. H. Floyd, J. A. Zambrano, A. M. Antó, C. Sandoval, C. P. Solórzano, and A. L. Díaz, "Identificación de las barreras del entorno que afectan la inclusión social de las personas con discapacidad motriz de miembros inferiores," vol. 28, no. 2, pp. 227–237, 2012.
- [3] L. F. Berrocal Mora and E. Al, "En Colombia, el 61% de las personas con discapacidad no recibe ningún tipo de ingreso económico para su subsistencia, es necesario que como sociedad les brindemos más oportunidades laborales," *Informe Especial de la Fundación Saldarriaga Concha*. [Online]. Available: <http://www.agenciapandi.org/en-colombia-el-61-de-las-personas-con-discapacidad-no-recibe-ningun-tipo-de-ingreso-economico-para-su-subsistencia-es-necesario-que-como-sociedad-les-brindemos-mas-oportunidades-laborales/>. [Accessed: 01-Oct-2014].
- [4] F. S. F. de B. Fundación Saldarriaga Concha, *La discapacidad en el contexto del Sistema General de Seguridad Social en Salud en Colombia: Lineamientos, epidemiología e impacto económico*, Gabriel Ca. Bogotá: Fundación Saldarriaga, 2009.
- [5] J. Padayachee, G. Bright, and L. J. Butler, "The Development of a Mechatronic Control System for Modular Reconfigurable Machine Tools," p. 8, 2009.
- [6] J. Kathirvelan, R. Anilkumar, Z. C. Alex, and A. Fazul, "Development of low cost automatic wheelchair controlled by oral commands using standalone controlling system," *2012 IEEE Int. Conf. Comput. Intell. Comput. Res.*, pp. 1–4, Dec. 2012.
- [7] A. Ye, W. Zou, K. Yuan, Z. Xu, and Y. Ren, "A reconfigurable wheelchair/bed system for the elderly and handicapped," *2012 IEEE Int. Conf. Mechatronics Autom.*, pp. 1627–1632, Aug. 2012.
- [8] N. Nakazawa, I. Kim, Y. Shibamiya, T. Matsui, T. Iwata, and K. Yamada, "Development of an interface based on face orientations for operation of auto-wheelchair," *2010 Int. Symp. Optomechatronic Technol.*, pp. 1–5, Oct. 2010.
- [9] C.-L. Chang, C.-C. Chen, C.-Y. Chen, and B.-S. Lin, "Kinect-based Powered Wheelchair Control System," *2013 4th Int. Conf. Intell. Syst. Model. Simul.*, pp. 186–189, Jan. 2013.
- [10] S. Hernández, L. Fernando, T. San, M. Christopher, U. S. Guillermo, R. Á. Beatriz, and D. F. México, "Rediseño para la Optimización de una Silla de Ruedas Eléctrica de Dos Posiciones .," *10º Congr. Nac. Mecatrónica*, pp. 90–96, 2011.
- [11] G. de las Nieves and N. Guerrero, "Capítulo 18 Matrices para la evaluación y selección de alternativas," [http://www.capac.org/web/Portals/0/bibliotec\\_a\\_virtual/doc004/CAPITULO%2018.pdf](http://www.capac.org/web/Portals/0/bibliotec_a_virtual/doc004/CAPITULO%2018.pdf), no. Fecha de consulta: 25 de agosto de 2013, pp. 197–223, 2003.
- [12] R. E. Cano, J. P. Hincapié, and J. I. García, "Caracterización de requisitos funcionales de una silla de ruedas eléctrica usando técnicas del diseño de productos centrado en el usuario," *Memorias VIII Congr. Latinoam. Ing. Mecánica, COLIM 2014*, vol. 2, no. ISBN: 978–9978–10–201–5, pp. 1278–1285, 2014.

- [13] ICONTEC, "NTC 4265 - Silla de ruedas. Determinación de la estabilidad estática," pp. 1–8, 1997.
- [14] ICONTEC, "NTC 4266 - Silla de ruedas. Determinación de la eficiencia de los frenos." Colombia, pp. 1–7, 1997.
- [15] ICONTEC, "NTC 4267 - Sillas de ruedas tipo. Determinación de las dimensiones totales, masa y espacio de giro," pp. 1–7, 1997.
- [16] ICONTEC, "NTC 4268 - Silla de ruedas. Clasificación por tipo con base en características de aspecto," 1997.
- [17] ICONTEC, "NTC 4269 - Sillas de ruedas. Dimensiones totales máximas," pp. 1–6, 1997.
- [18] Autodesk, "Autodesk ForceEffect," <https://forceeffect.autodesk.com/FE.html>, 2013.
- [19] J. J. Croney, *Antropometría para diseñadores*. Editorial Gustavo Gili, 1978.
- [20] J. L. Melo, "Ergonomía - El Asiento - Parte 07 - 11," <http://www.estrucplan.com.ar/Producciones/entrega.asp?IdEntrega=2393>, no. Fecha de consulta: 16 de Febrero de 2014, 2007.
- [21] L. Ningbo Hansen Co., "Sinomotors," <http://www.sinomotors.com/>, no. Fecha de consulta: 15 de marzo de 2014.
- [22] Mathworks, "MATLAB - The Language of Technical Computing 64 bits," <http://www.mathworks.com/>, 2010.
- [23] 3DS, "ABAQUS/ CAE 6.12-1 64 bits," <http://www.3ds.com/about-3ds/>, 2009.
- [24] Autodesk, "Professional Inventor 2014| Software de CAD 3D | Autodesk 64 bits," <http://www.autodesk.es/products/autodesk-inventor-family/overview>, 2014.
- [25] F. P. and C. Shigley, Joseph Edward and Mischke, Charles R and Bocanegra, *Diseño en ingeniería mecánica*. México: McGraw-Hill, 2002.
- [26] P. y P. Stevens, *Utilización de UML en Ingeniería del Software con Objetos y Componente*, 1er ed. Addison Wesley, 2007.
- [27] U. D. E. C. Station, "IDEF Family of Methods A Structured Approach to Enterprise Modeling & Analysis," *Idef0 Method report*, 2010. [Online]. Available: <http://www.idef.com/>. [Accessed: 20-Mar-2014].
- [28] T. Murata, "Petri Nets : Properties , Analysis and Applikations," vol. 77, no. 4, pp. 541–580, 1989.
- [29] Hincapié J. P.1, C. R. E., and G. J. I, "Adaptación tecnológica en una silla de ruedas de accionamiento eléctrico al contexto colombiano," *Memorias del XI Congr. Iberoam. Ing. Mec. CIBIM 2013*, vol. 1, 2013.
- [30] R. E. C. Buitrón, J. P. H. Villada, and J. I. G. Melo, "Especificación de una Adaptación Tecnológica a una Silla de Ruedas Eléctricas Aplicando un Enfoque Modular," *Memorias del XII Congr. Int. sobre Innovación y Desarro. tecnológico, CIINDET 2015*, vol. 1, no. Pendiente por ISBN, 2015.
- [31] J. L. J. Marc Faure, "Methods for safe control systems design and implementation," *10th IFAC*, vol. Version 1, p. 6, 2001.
- [32] CPNTools, "cpntools.org," <http://cpntools.org/>, no. Fecha de consulta: 24 de julio de 2014.
- [33] J. Pardue, "C Programming for Microcontrollers," *Smiley micros*, 2005.
- [34] L. Electronics, "Proteus 8.0 - Professional PCB Design and Simulation Software 64 bits," <http://www.labcenter.com/index.cfm>, 2012.
- [35] Atmel, "Datasheet ATmega32 ( L )." p. 346, 2011.
- [36] ISO, "ISO 7176," <http://www.iso.org/iso>, no. Fecha de consulta: 5 de diciembre de 2014.
- [37] MAXM, "Datasheet Maxm RS-485/RS-422 Transiver." pp. 1–16.